

**Introduction:** Understanding the atmospheric oxidation of organic compounds is important for predicting the production of tropospheric ozone and organic aerosols, both of which impact our health and climate. Though the formation of these two constituents involves many compounds, isoprene plays a dominant role due to its large biogenic emissions and rich oxidative chemistry. However, it is the complexity of its oxidation scheme that serves as a major source of uncertainty when making predictions, generating chemical models that fall short of replicating ambient observations especially near isoprene-dominated environments<sup>1</sup>.

One reason for this uncertainty is due to its peroxy radical (ISOPO<sub>2</sub>), formed predominantly through the oxidation of isoprene with OH. ISOPO<sub>2</sub> is known to undergo three individual reaction pathways, with the likelihood of each strongly dependent on the availability of NO<sub>x</sub>. In areas where NO<sub>x</sub> levels are decreasing (e.g., the United States), the isoprene chemistry is being shifted towards a system dominant in autoxidation and HO<sub>2</sub> reactions, resulting in the production of species such as isoprene epoxides (IEPOX), which contribute to the formation of secondary organic aerosols<sup>2</sup>. Analogously, as NO<sub>x</sub> emissions increase in more pristine areas (e.g., the tropics) ISOPO<sub>2</sub> begins to favor its reaction with NO, either increasing the ozone production potential of the area or forming reservoirs, like isoprene nitrates (ISOPN), that can transport NO<sub>x</sub> elsewhere with unknown effects.

Observations of ISOPO<sub>2</sub> products in the atmosphere can shed light on the relative importance of the reaction pathways that produce them. The utilization of clustering ion chemistry in conjunction with chemical ionization mass spectrometry (e.g., CF<sub>3</sub>O<sup>-</sup> CIMS) has allowed low fragmentation sampling of important multifunctional isoprene products considered too fragile to be detected otherwise<sup>3</sup>. However, because isoprene oxidation results in eight ISOPO<sub>2</sub> isomers, CIMS cannot distinguish between the isomeric products, causing ambiguity in the data provided and leaving unanswered

questions about the fate of ISOPO<sub>2</sub> in differing NO<sub>x</sub> regimes.

To combat this, I aided in the development of a field-hardened high resolution time-of-flight CF<sub>3</sub>O<sup>-</sup> CIMS coupled with a low pressure gas chromatograph (GC-HR-ToF) that is capable of observing isomer distributions of various oxidation products in ambient air. An initial field test has provided promising preliminary chromatograms of several isoprene products and my plans to continue the development of this instrument will allow it to serve as an invaluable analytical tool, allowing for an increased understanding of ISOPO<sub>2</sub> chemistry and its effects on global air quality.

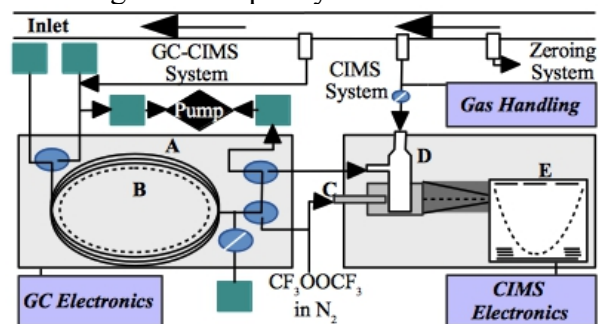

**Figure 1:** Instrument schematic of GC-HR-ToF. Green boxes represent mass flow controllers; blue circles represent valves; arrows indicate direction of analytical flow. (A) GC column; (B) Heating/cooling unit; (C) Radioactive ionizer; (D) Glass flowtube; (E) ToF mass analyzer.

**Instrument Description:** The GC-HR-ToF uses a 1-meter column with its resulting effluent sampled directly into the CIMS. During collection, the sample is cryofocused near the entrance of the column via a custom-built heating/cooling unit and the temperature of the cold trap is controlled through alternating CO<sub>2</sub> cooling and resistive heating. Furthermore, during the trapping phase, ambient air is also simultaneously analyzed by the CIMS, allowing for direct comparison between the GC sample and traditional measurements. The overall instrument schematic is shown in Figure 1, with a focus on the GC components I constructed.

**Preliminary Results:** Our first field test occurred during PROPHET 2016, a campaign held at the University of Michigan Biological Station. Sitting on the PROPHET tower 30 meters

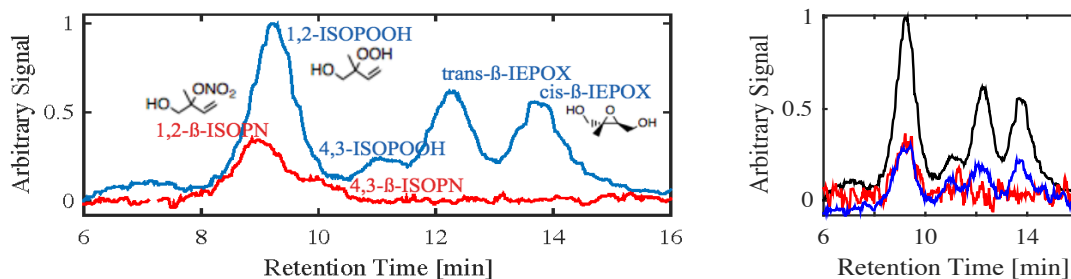

**Figure 2:** (A) Peak assignment of ISOPOOH/IEPOX (blue) and ISOPN (red, signal x3) for data collected on 23 July, 10:00 EDT; (B) Sample of peak identification of ISOPOOH/IEPOX (black) using known product ions (red & blue, signal x2) from data collected on 23 July, 14:00 EDT

above ground, the GC-HR-ToF sampled above the tree canopy obtaining flux measurements of various compounds. Even more, *in situ* isomer distributions of isoprene products (e.g. isoprene hydroxy hydroperoxides (ISOPOOH), IEPOX and ISOPN) were observed for the first time in ambient data. I have performed preliminary peak assignment using known product ions<sup>2</sup> to identify the compounds (Figure 2). The isomer distributions determined by this data set will provide information regarding the fate of ISOPO<sub>2</sub> in a Northern Michigan forest influenced by both pristine air from the north and high-NO<sub>x</sub> pollution from nearby urban centers.

**Research Plan:** Though overall successful in the field, I plan to further improve the GC cryotrapping system. Despite the fact that the column separated the product isomers, the high humidity levels seen in Michigan served as a major obstacle during sample collection; trapped water easily degrades the chromatography by hydrolyzing isomers and overshadowing the visibility of early eluting peaks. Though I performed constant on-site adjustment to minimize this effect in the field, improvement of the temperature control and automating its adjustment with ambient humidity will make the GC system more robust in the field.

Afterwards, I propose to commission the instrument to continuously sample ambient air on Caltech campus (an urban high NO<sub>x</sub> environment) while also preparing for a summer collaboration at Indiana University (a rural low NO<sub>x</sub> regime). During both field experiments, as well as with future campaigns, the GC-HR-ToF will

be able to obtain isomer-specific measurements of isoprene products in areas with a spectrum of NO<sub>x</sub> concentrations. This will be key in understanding both the favorability of ISOPO<sub>2</sub> pathways and its subsequent effects on air quality, particularly in areas where VOC/NO<sub>x</sub> ratios can be effected by increasing emissions, the transport of NO<sub>x</sub> or air quality regulations.

**Conclusion & Broader Impacts:** The data I will obtain using the GC-HR-ToF will provide a critical test of our current grasp of isoprene chemistry, adding to the current kinetics used in models to improve predictions. In addition, its use by several atmospheric groups at Caltech, as well as collaborators, will extend the use of this new technique beyond our initial focus, demonstrating both its versatility and benefit to the scientific community.

Lastly, as this instrument aims to better understand some of the fundamental science behind isoprene chemistry, it provides an opportunity for me to enhance my science communication skills. By using my blogging platform, I plan to discuss the various aspects of atmospheric chemistry and atmosphere-biosphere interactions in order to teach a demographic composed of young students and future scientists about a field they may have otherwise never been introduced to. Additionally, social media has been and will continue to be utilized when out in the field to give my readers a peak into the day to day workings of an atmospheric chemist. **References:** (1) Horowitz, L. W. *et al.* JGR: Atmos. 112, 13 (2007). (2) Bates, K. H. *et al.* JPCA 118, 1237-1246 (2014). (3) Crounse, J. D. *et al.* Anal. Chem. 78, 6726-6732 (2006).